

US Patent # 3,697,190

Truncated Conical Drag Pump

US Cl. 415/73 (October 10, 1972)

Walter D. Haentjens

Abstract ---

High pressure low volume rate drag pump having a frusto-conical rotor cooperating with a frusto-conical stator wall and having close clearance with the stator wall. The rotor has a helical channel extending therealong, in which the base or root of the channel is formed along a different angle than the cone angle of the rotor. The high pressure is attained by the maximum drag surface along the relatively small passageways together with the centrifugal force of the fluid due to increasing linear velocity of the rotor from its inlet to its discharge end. The rotor is axially adjustable to maintain a close clearance and a high pressure capability of the pump.

The Field of the Invention

This invention relates generally to low capacity high pressure rotary pumps.

Background, Summary and Objects of Invention

The pump of the present invention operates on the principles of a dynamic shaft seal in which a shaft is provided with square threads on its ends to be seals, which threaded end rotates within a closed chamber. The effectiveness of the seal is directly dependent upon the radial clearance and the pressure delivered is inversely proportional to the square of the radial clearance. While such seals generate high pressure and are in effect a pump operating against a shut-off condition, it has not been possible to provide a means for compensating for wear or for reducing the clearance between the rotor and stator to maintain the efficiency required by a high pressure pump. As is evident from the above relationship, an increase in radial clearance, as would occur with wear, rapidly reduces the pressure available.

The present invention utilizes but improves upon the features of the dynamic seal, in that it places the channels or threads at an angle, which matches a corresponding stator angle. The rotor may thus be a cone or the frustrum of a cone. Axial adjustment means are provided to axially adjust the rotor relative to the conical wall of the stator, to enable the clearance between the rotor and stator to be controlled. The rotor may thus be operated with very close clearances between the rotor and stator wall and the centrifugal force created by the increasing diameter of the rotor from its inlet adds a pressure component to the pressure attained by the drag of the fluid along the walls of the channel.

The pump, therefore, operates on the principle of maintaining a constant slip velocity between channel walls of the rotor and the fluid, in which the channel depth varies, so that the velocity of the fluid changes in accordance with the peripheral velocity of the channel walls of the rotor.

A principal object of the present invention is to provide a more efficient and practical high pressure low capacity pump by the use of a conical channeled rotor having close

clearance with the conical wall of a stator.

A further object of the invention is to provide a novel and improved form of low volume high pressure rotary pump of the truncated conical variety, in which the pressure available is a combination of that produced by the hydraulic drag and the centrifugal action on the fluid resulting from the increase in peripheral speed of the rotor due to the change in radius of the truncated conical rotor of the pump.

A further object of the invention is to provide a simplified form of pump having a conical rotor cooperating with a frusto-conical stator with helical channels extending along the rotor, in which the bases or roots of the channels are formed along a different angle than the angle of the rotor, to provide a constant volume of fluid in the passageways from the inlet to the discharge end of the pump with a substantially constant hydraulic drag as the fluid progresses from the inlet to the outlet end of the rotor.

A still further object of the invention is to utilize a conical drag pump in place of the conventional positive displacement reciprocating pump for attaining a high pressure, by providing a frusto-conical rotor having at least one helical channel extending therealong from the inlet to the outlet end of the rotor, in which the efficiency of the pump is maintained by the reduction in clearance between the rotor and stator wall, and the clearance may be controlled within fine limits by axially adjusting the rotor relative to the stator wall.

A further improvement is the use of two or more helical channels, arranged so that radial hydraulic balance exists, thus permitting an extremely close operating clearance between the rotor and stator.

Other objects, features and advantages of the invention will be readily apparent from the following description of a preferred embodiment thereof, taken in conjunction with the accompanying drawings, although variations and modifications may be effected without departing from the spirit and scope of the novel concepts of the disclosure.

Description of the Drawings

Figure 1 is a longitudinal sectional view taken through a pump constructed in accordance with the principles of the present invention, with the rotor shown in solid;

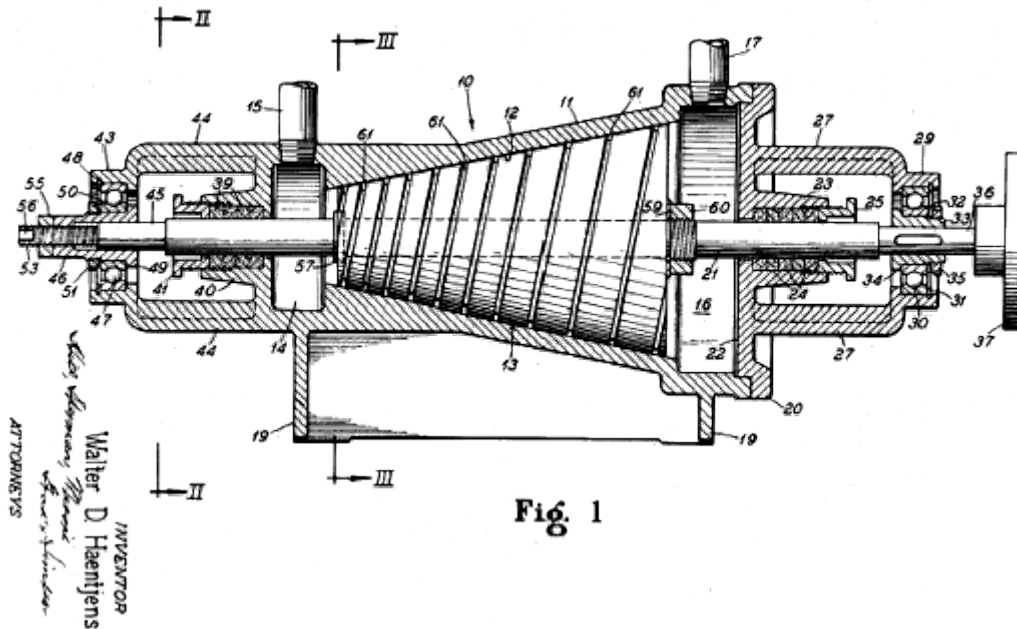

Fig. 1

Figure 2 is a sectional view taken substantially along line II-II of Figure 1;

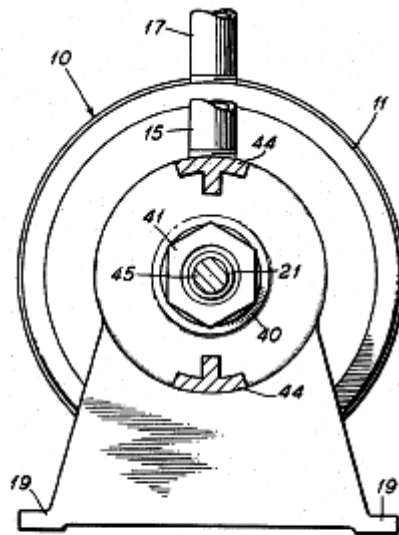

Fig. 2

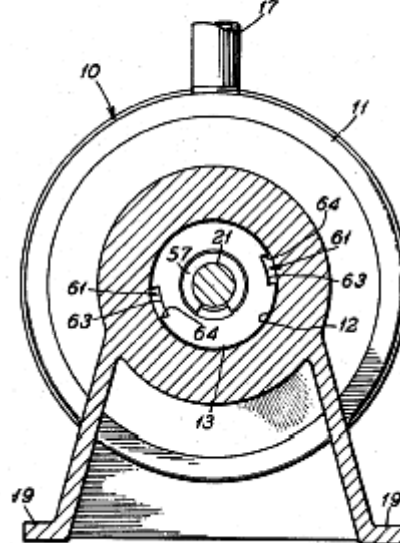

Fig. 3

Figure 3 is a sectional view taken substantially along line III-III of Figure 1; and

Figure 4 is a diagrammatic view illustrating the difference between the cone angle and thread angle at the base of the channels, compensating for increased drag velocity and increased diameters and peripheral speed from the inlet to the outlet end of the rotor.

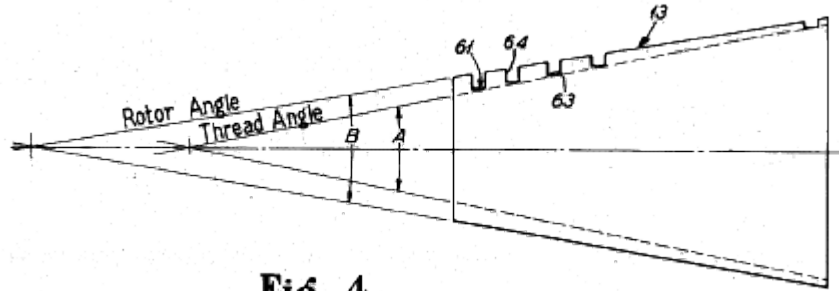

Fig. 4

INVENTOR
Walter D. Haentjens

Description of a Preferred Embodiment of Invention

In the embodiment of the invention illustrated in the drawings, I have shown in Figure 1, a conical drag pump 10 including a housing 11 having a frusto-conical interior wall portion 12 forming a pumping chamber and cooperating with a frusto-conical rotor 13 to produce a high pressure of the fluid as discharged through the outlet of the pump. An inlet chamber 14 is provided at the small diameter end of the frusto-conical wall portion 12 and is shown as having an outlet pipe 17 leading therefrom. The housing 11 is supported on feet 19, which may be bolted or otherwise secured to a conventional foundation or base (not shown).

The outlet chamber 16 is closed by a detachable end cap 20, suitably sealed thereto and removable to afford access to the frusto-conical wall 12, to accommodate machining thereof and assembly of the rotor 13 and a rotor shaft 21 within said housing with the wall of said rotor in close clearance with the internal frusto-conical wall 12.

The end cap 20 has a wall portion 22, closing the outlet end of the housing, and having a cup-like boss 23 extending outwardly therefrom. The cup-like boss 23 contains packing 24, contained to said cup-like boss as by an adjustable gland nut 25 threaded in said boss. The end cap 20 also has a pair of bracket arms 27 extending axially outwardly therefrom. The bracket arms 27 may be formed integrally with the end cap 20 and are spaced apart to afford access to the gland nut 25, to take up on the packing 24. The bracket members 27 form a support at their outer edges for a bearing boss 29 for an anti-friction bearing 30. The bearing 30 is shown as retained against a shouldered position of said bearing boss as by a snap ring 31.

The bearing 30 may be a conventional form of ball bearing and has an inner race 32 mounted on a sleeve 33 and retained against a shouldered portion 34 of said sleeve as by a retainer nut 35 threaded on the outer end of said sleeve and suitable locked thereto. The shaft 21 has a reduced diameter outer end portion 36 extending through the sleeve 33, with a close sliding fit extending outwardly therefrom. The sleeve 33 may be feather keyed on the reduced diameter end of the shaft 36 and sufficient clearance may be provided between the shaft and the sleeve 33 to accommodate axial movement of said shaft relative to said sleeve when taking up on clearance between the frusto-conical wall 12 and frusto-conical face of the rotor 13. The reduced diameter end portion 36 of the shaft 21 is shown as having a coupling 37 mounted thereon, coupling said shaft to a suitable motor (not shown) for driving said shaft and the rotor 13. The coupling 37 may be of a conventional form, of a type which will permit some axial movement of the shaft 21 relative to the motor shaft upon adjustment of clearance between the rotor and the frusto-conical wall 12, and which will also compensate for temperature changes. It should be understood that the coupling 37 may be at either end of the shaft, although the present location of said coupling is preferred to facilitate axial adjustment of said shaft and the rotor 13 relative to the frusto-conical wall 12.

The opposite end of the shaft 21 from the coupling 37 extends through the inlet chamber 14 and is sealed by packing 39 contained within a cup-like retainer 40 extending outwardly of the inlet end wall portion of the housing 11. The packing 39 may be taken up by a gland nut 41 threaded within the interior wall portion of said cup-like retainer 40.

A bearing boss 43 is spaced outwardly of the packing nut 41 and is supported by integrally formed bracket arms 44, extending axially outwardly of the inlet end of the housing 11 and shown as being formed integrally with said housing. The spaced bracket arms 44, like the bracket arms 27, afford access to the gland nut 41, to accommodate adjustment of the packing 39.

The end of the shaft 21 extending outwardly of the gland nut 41 has a reduced diameter portion 45 having sliding fit with a bearing sleeve 46, for a bearing 47 mounted in the bearing boss 43. The bearing 47 may be a suitable form of anti-friction bearing, such as a ball bearing and is shown as retained against an inner shouldered position of the bearing boss 43, as by a snap ring 48.

The sleeve 46 has an inner flanged portion 49 forming a shoulder abutted by an inner race 50 of the bearing 47. A nut 51 threaded on said sleeve is provided to lock said inner race to said sleeve and against the shoulder formed by the flange 49.

The outer end portion of the sleeve 46 is internally threaded, and is threaded on a reduced diameter outer end portion 53 of the shaft 21. A lock nut 55 locks said sleeve to said shaft to effect rotation of said sleeve upon rotation of said shaft. The threaded end portion 53 of the shaft 21 may have opposite flat faces, one of which is indicated by reference numeral 56, to accommodate axial adjustment of said shaft relative to the sleeve 46 by loosening the lock nut 55 and holding the shaft from rotation by a wrench engaging the flat portions 56 thereof, and then turning the sleeve 46 along said shaft, to achieve the desired radial clearance between the face of the rotor 13 and the interior cylindrical wall 12.

The rotor 13 may be keyed or otherwise secured to the shaft 21 and is held on said shaft by a split or snap ring 57 snapped on said shaft and engaging the small diameter end of the rotor 13, and by a washer 59 abutting the large diameter end of said rotor, and held thereto as by a nut 60 threaded on said shaft and suitably locked thereto.

The rotor 13 has at least one helical channel 61 cut or otherwise formed therein and leading from the inlet to the outlet end of said rotor. As shown in Figures 1 and 3, two diametrically opposed channels are shown as being in the form of double square threads, each of which threads or channels have a root or base 63 and parallel side walls 64. The channels, however, need not necessarily be formed like square threads but may have rounded bases or may be of various other forms.

While I have shown two helical channels herein, it should be understood that the pump is not restricted to one or two helical channels but that the rotor may have three or more helical channels, provided they are spaced equal distances apart to effect a balance of the changes in pressure as fluid progresses along the channels to the discharge end of the pump.

In order to compensate for the increasing diameter of the rotor from the inlet to the outlet thereof, the channels 61 are set at a different angle from that of the rotor. As for example, in Figure 4, this angle is diagrammatically illustrated by reference character A and the angle of the frusto-conical face of the rotor is designated by reference character B. The difference in cone angle from the thread angle thus adjusts the geometry of the threads according to the radius of the cone and the channels or threads 61 are of the same width throughout the length of the cone. The depth, however, decreases as the radius increases, to maintain a substantially constant slip velocity between the passage walls of the rotor and the fluid.

As previously mentioned, the pressure obtainable by the pump is basically due to the drag of the fluid along the walls of the channel, and the decreasing depth of the channel as it approaches its discharge end adjusts the geometry according to the radius to provide a constant hydraulic drag, as the fluid progresses from the inlet to the outlet end of the rotor.

The pressure generated from the present truncated conical drag pump, therefore, is a combination of that produced by a dynamic seal and the centrifugal force resulting from the increase in peripheral speed due to the increasing radius of the truncated conical

Portail EnergyThic

Free Energy Engines Engineering

rotor from its inlet to its discharge end.

The pressure produced by the unit is, therefore, controllable by the rotative speed of the rotor, the thread diameter and the thread length and the pressure obtainable is exponentially dependent upon close radial clearance between the periphery of the rotor and internal frusto-conical wall of the stator, which can be adjusted and maintained by holding the shaft 21 stationary and turning the sleeve 46 along the threaded end portion of the shaft and then locking the sleeve to the shaft by the lock nut 55.

It should be understood that while I herein show the channels cut at a different angle from that of the face of the cone, and show what are in effect square threads, that the channel may be cut in the same angle as the cone angle and the desired thread geometry may be attained by varying the width or shape of the channels from the inlet to the outlet end of the rotor.

I claim as my invention: [Claims not included here]